

CONGELADOR HORIZONTAL NO FROST TFI-3200FC

ilumi
equipamiento comercial



Foto referencial

Características

- 2 canastillas
- Refrigerante ecológico R134a
- Temperatura dual: 0°C a 10°C y de 0°C a -20°C.
- Compresor de alto performance, permite ahorrar energía
- Base con ruedas
- Chapa con llave

Plano mecánico

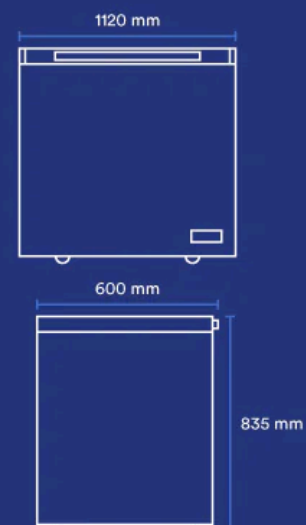

Datos técnicos

Medidas de embalaje (mm)	An.1163xFo.659xAl.880
Peso neto	42 Kg
Peso bruto	48 Kg
Capacidad	320 Lts
Voltaje	220-240V - 60HZ
Consumo de energía	1.5Kwh/24H